



# INSTRUCTION MANUAL

For **Counter Top Merchandiser**

CTD-3

CTD-3S

CTD-5

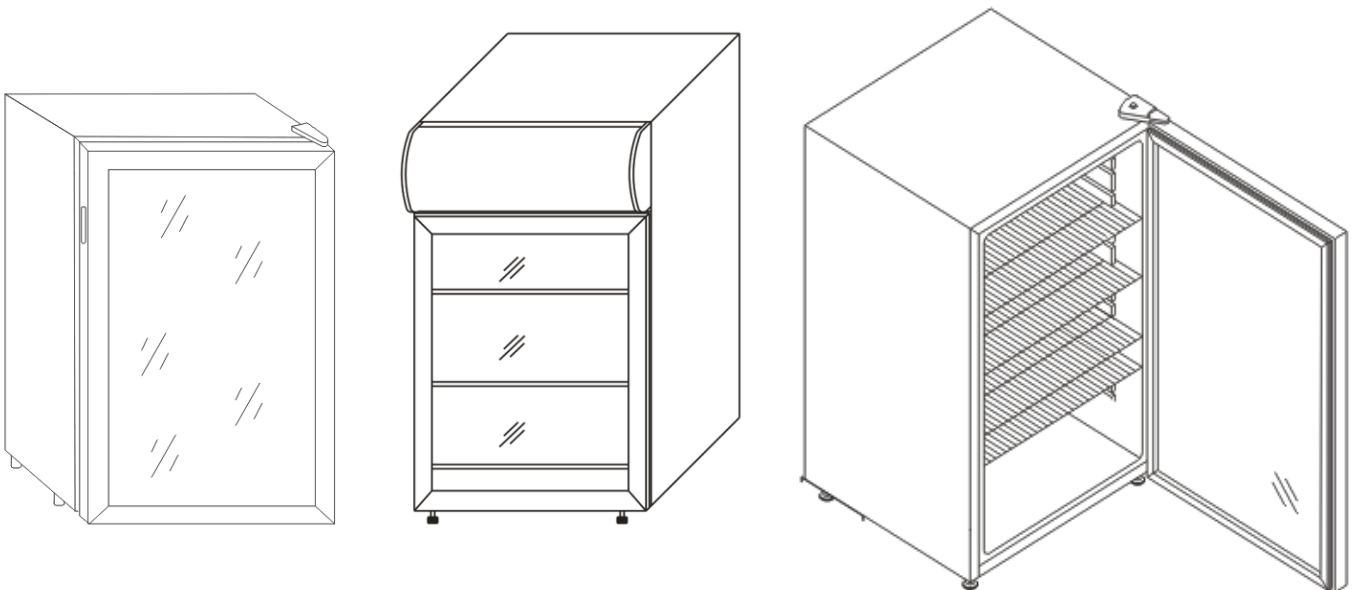

Please read this user's manual thoroughly before using.

Keep this manual handy for further reference.

Email: [warranty@atosausa.com](mailto:warranty@atosausa.com)

Toll Free: 1-800-683-8660 (USA)

855-885-6518 (Canada)

# Warranty Information

## One YEAR WARRANTY

All claims for parts or labor must be made directly through Atosa. All claims must include the model number of the unit, serial number, proof of purchase, date of installation. and all pertinent information supporting the alleged defect. In case of a compressor replacement under warranty. either the compressor or compressor tag must be returned to Atosa along with above listed information.

**Failure to comply with warranty policies will result in voiding claims.**

### One Year Parts & Labor Warranty

Atosa warrants all new refrigerated components such as the cabinet and all parts, to be free from defects in materials or workmanship. Atosa's obligation under this warranty is limited to a period of one (1) years from the date of original installation or 15 months after shipment date from Atosa or, whichever occurs first. All parts covered under this warranty that are defective within one(1) years of original installation or fifteen (15) months after shipment date from manufacturer, whichever occurs first, are limited to repair or replacement (including labor charges, of defective parts or assemblies) The labor warranty shall include standard straight time labor charges only and reasonable travel time, as determined by Atosa.

### Additional Four-Year Compressor Warranty

In addition to the one(1) Year warranty stated above. Atosa warrants its sealed compressor to be free from defects in both material and workmanship under normal and proper use and maintenance service for a period of four (4) additional years from the date of original installation, but not to exceed five (5) years. Compressors that have been determined to be defective from Atosa within this extended period will be either repaired or replaced with a compressor or compressor parts of similar design and capacity according to Atosa's discretion . The four (4) year extended compressor warranty applies only to sealed parts of the compressor and does not apply to any other parts or components. This includes. the cabinet, paint finish, temperature control, refrigerant, metering device, motor starting equipment, fan assembly and other electrical components, etc.

### Compressor Warranty

The five-year compressor warranty detailed above will be void if the following procedure is not carefully adhered to:

- 1.This system contains refrigerant and lubricant. The lubricant has rapid moisture absorbing qualities.
- 2.Drier replacement is very important and must be changed when a system is opened for servicing.
- 3.Micron level vacuums must be achieved to insure low moisture levels in the System.
- 4.Compressor must be obtained through Atosa unless otherwise specified in writing through Atosa's warranty department.

### What is Not Covered by This Warranty

Atosa's sole obligation under this warranty is limited to either repair or replacement of parts, subject to the additional limitations below. This warranty neither assumes nor authorizes any person to assume obligations other than those expressly covered by this warranty.

**NO CONSEQUENTIAL DAMAGES:** ATOSA IS NOT RESPONSIBLE FOR ECONOMIC LOSS; PROFIT LOSS; OR SPECIAL. IN DIRECT, OR CONSEQUENTIAL DAMAGES,INCLUDING WITHOUT LIMITATION, LOSSES. OR DAMAGES ARISING FROM FOOD OR PRODUCT SPOILAGE,REGARDLESS OF WHETHER OR NOT THEY RESULT FROM REFRIGERATION FAILURE.

**WARRANTY IS NOT TRANSFERABLE:** This warranty is not assignable and applies only in favor of the original purchase /user to whom delivered. ANY SUCH ASSIGNMENT OR TRANSFER SHALL VOID THE WARRANTIES HEREIN AND SHALL VOID ALL WARRANTIES. EXPRESS OR IMPLIED. INCLUDING ANY WARRANTY OF MERCHANTABILITY OR LABOR COVERAGE FOR COMPONENT FAILURE OR OTHER THE WARRANTY PACKET PROVIDED WITH THE UNIT.

ALTERATION, NEGLIGENCE, ABUSE, MISUSE, ACCIDENT, DAMAGE DURING TRANSIT OR INSTALLATION, FIRE, FOOD, OR ACTS OF GOD:

Atosa is not responsible for the repair or replacement of any parts that are determined to have been subjected after the date of manufacture to alteration, neglect, abuse, misuse, accident, damage during transit or installation, fire, flood, or act of God.

**IMPROPER ELECTRICAL CONNECTIONS:**Atosa IS NOT RESPONSIBLE FOR THE REPAIR OR REPLACEMENT OF FAILED OR DAMAGED COMPONENTS RESULTING FROM ELECTRICAL POWER FAILURE, THE USE OF EXTENSION CORDS, LOW VOLTAGE, OR VOLTAGE DROPS TO THE UNIT.

THE ONE(1) YEAR PARTS & LABOR WARRANTY AND THE ADDITIONAL FOUR (4) YEAR COMPRESSOR WARRANTY ARE AS DESCRIBED ABOVE. THESE WARRANTIES ARE EXCLUSIVE AND IN LIEU OF ALL OTHER WARRANTIES, INCLUDING IMPLIED WARRANTY AND MERCHANTABILITY OR FITNESS FOR A PARTICULAR PURPOSE. THERE ARE NO WARRANTIES WHICH EXTEND BEYOND THE DESCRIPTION ON THE FACE HEREOF.

**Outside U.S. and Canada:**This warranty does not apply to areas outside the continent of the United States. Atosa is not responsible for any warranty claims made on products sold or used in such areas.

\*In some cases, a 25 % restocking fee may be charged to a buyer for returned items.\*

Atosa may at any time modify our equipment in order to provide and insure a superior product. Change is sometimes necessary to keep up with today's high standards in our industry. Atosa reserves the final interpretation of all public material.



### **Important Child Safety**

Destroy or recycle the carton, plastic bags, and any exterior wrapping material immediately after the unit is unpacked. Children should **never** use these items to play.

# Product Information

## --Structural diagram

CTD-3

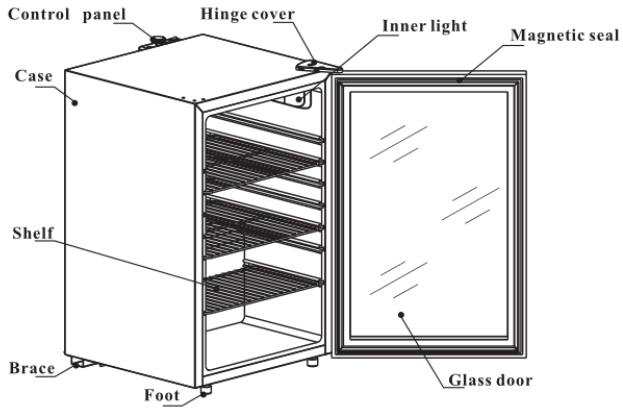

CTD-3S

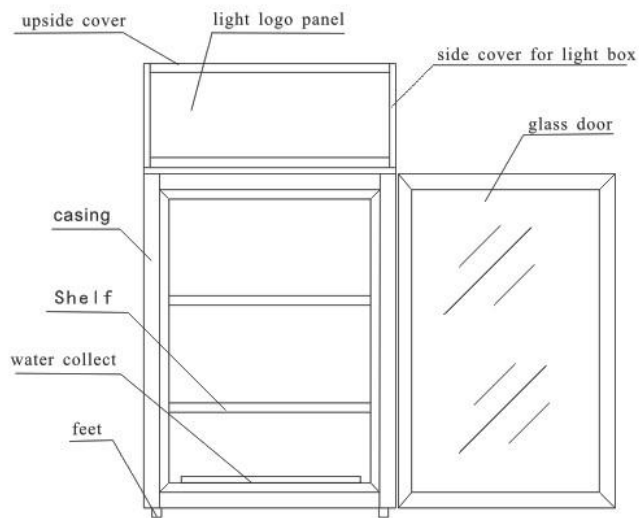

CTD-5

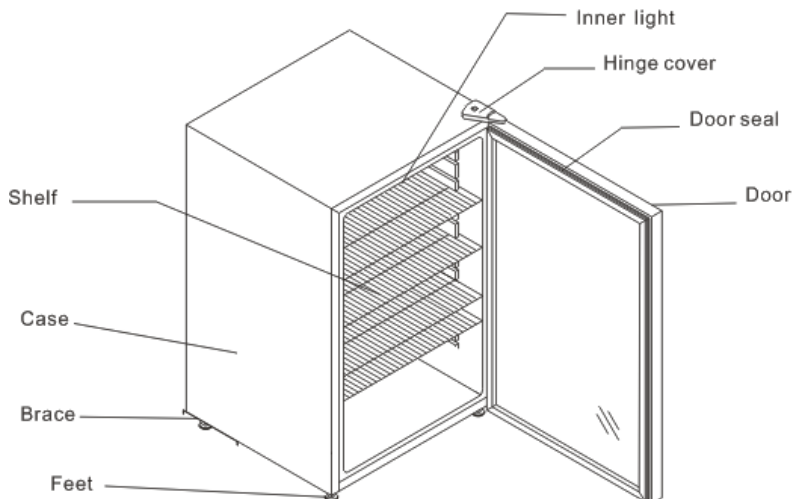

## --Technical Specification

Model	CTD-3	CTD-3S	CTD-5
Rated Electric	115v, 60Hz, 1.5A	115v, 60Hz, 1.5A	115v, 60Hz, 1.7A
Refrigrant(Ounces)	R600a / 1.06	R600a / 1.16	R600a / 1.58
Design Pressure(High/Low)	280 psig / 90 psig	280 psig / 90 psig	280 psig / 90 psig
Net weight(KG)	24	29	40

## --Safe Cautions

1. This unit uses AC110V/60Hz power, there should be a 500va stabilizer if the voltage fluctuation exceeds AC99V-132V
2. The user should hold the plug when the power is on /off, dragging or pulling the power cord is prohibited.
3. Do not remove the power cord or plug
4. Must use dependent socket and reliable ground wire. Ground wire must not connect with the null line of the gas pipe, warm gas pipe, water pipe and must be single power
5. Never splash water on the unit directly.
6. Keep away from explosive, hazardous goods such as ether, gas, alcohol, bonding agents, gunpowder etc.
7. Keep away from spray of inflammables such as paints, coating materials etc.
8. After the unit is switched off, it should not be restarted within 5 minutes.
9. Do not leave the power cord under any heavy objects including the unit itself.
10. Do not drill holes or install other objects on the casing.
11. This cooler is not suitable for storage pharmaceutical products.

## --Portage and storage

1. Keep the unit vertical when carrying the unit, the angle to the horizontal line should not be over  $50^{\circ}$  , otherwise it will damage the compressor and affect normal operation of the unit.
- 2.The unit should be place on a solid and firm ground, take away the bottom pack to lower the shock and noise.
- 3.Leave at least 20 cm of distance between the back of the unit and the wall for ventilation and leave a space with an open angle of  $160^{\circ}$  for the door.
- 4.Keep the unit away from heat sources and avoiding direct sunlight.
5. Never place the unit on a location where water can reach or with high moisture. Splashed water and dirt should be wiped off in time by using a soft cloth.
6. Do not place the unit in the environment cold enough to be iced.

## --Preparation

1. Remove the carton and packing foam (including the bottom foam)before using.
2. Clean the unit before using.
3. Adjust the foot to make the unit steady according to the ground condition to lower the shock and noise.

- After moving the unit, place the unit for 30 minutes before switching it on.  
Running: close the door and connect the power, turn on the lamp switch on the control panel, the lamp is on. Half an hour later, the temperature inside the case lower apparently, it indicates the unit on be normally used
- After connecting the power, the unit should be kept empty for one hour.

## --Setting and adjustment of temperature

- Adjust the storage temperature through the temperature controller located in the internal of the case(see the picture),adjust the temperature according to the ambient temperature and the foodstuff.
- See the following picture about the knob scale. The temperature adjustable capacity is from "1"- "5",adjust the storage temperature by turning the temperature controller clockwise. The higher of the number shows the lower of the storage temperature. The knob can turn freely but can't turn clockwise from "5"- "1". Factory setting position is on "3"

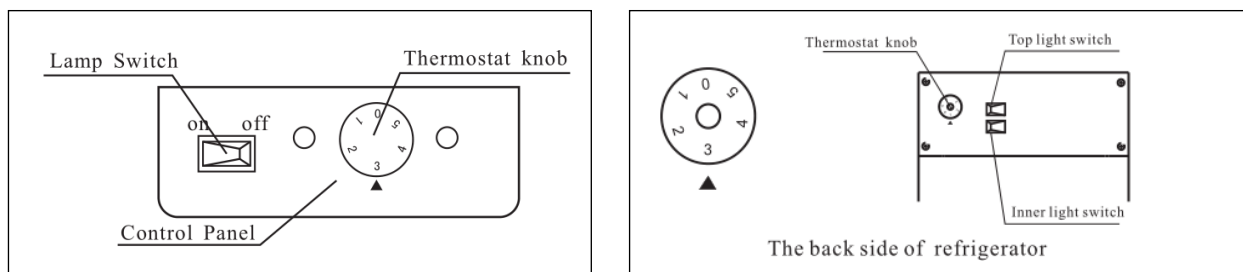

- Check if the scale is on an appropriate position before using, summer, the ambient temperature is high, anti-clockwise turn the knob to "2", while in winter, the ambient temperature is low, clockwise turn the knob to "4".
- Position "0" represent stop running.

## --Storage of articles

- Do not put large amount of articles into the unit at one time, you should leave some space around the foodstuff to let cold air inside the cabinet counter to flow. Keep bottled articles away from the walls of interior cabinet so as not to freeze it until broken.
- Do not put warm food into the unit directly until they are cooled under normal temperature, it will facilitate to lower its energy consumption and prolong service life of the compressor.

## --Maintenance

### Disconnect the power supply before maintenance for the machine!

- Keep the door gasket clean, remove it from the door and wash it. Dry and seal it as before. Putting some talcum powder on the magnetic surface would prolong its service life.
- Bulb replacement: remove the lamp shade, take out the bulb, replace with a new bulb, then mount it again.
- If there is heavy frost on the evaporator after long usage, take out the stuff inside the case, disconnect the power, the frost will melt automatically, clean up the water and connect the power again.
- Use a soft cloth and dip some water or soap (Non-caustic, neutral detergent is also available) to clean the unit. Dry the unit after cleaning to avoid rust.

- 5) Do not use organic liquid, boiled water, washing powder or acid stuff to clean the unit. Rinsing the case by water is not allowed, don't use hard brush, steel brush to clean the case.
- 6) If the unit will not be used for a long time, disconnect the power, clean it by following the above steps, wipe off the water inside the case with a soft cloth.

### **--Caution**

- 1) The unit is not suitable for storage of blood, pharmaceutical products and biological products
- 2) Do not place heavy articles on the top of the unit.
- 3) In case of trouble, please ask professional person for service, do not dismantle the unit without prior authority to avoid hazard

### **--Normal Phenomena**

- 1) Sometime hear light sound of water flowing in the unit, this is the sound of refrigerant flowing inside the pipe.
- 2) the top ,and the two sides of the casing will be warm, even too hot.
- 3) In a humidity place, there is dew on the casing or the door, it can dry by dry cloth.

### **--Troubleshooting guide**

<b>Problems</b>	<b>Possible cause</b>	<b>Ways to solve problems</b>
The units does not work	Bad connection of plug	re-connect the plug to power supply
Abnormal operation of the compressor or has buzz sound	The power voltage is out of the rated range.	Disconnect the power supply immediately and reconnect with it after normal voltage.It is necessary to have a voltage stabilizer in case of poor power supply.
Compressor operate too long time and no frost on the surface of inner cabinet	Refrigeration system is at fault(leakage or blocked)	Send the unit to service department for repair
There is frost or ice on the evaporator of the inner cabinet and too low internal temperature,the compressor operates never stop	Thermostat does not work	Ask service department for repair

The internal temperature is too high, and the compressor operation doesn't stop	Bad heat dissipation and ventilation of casing, the ambient temperature is too high	Improve ventilation and improve the ambient temperature
	Too much warm food was put in at one time	Take out some food
	Door open frequently and longtime door opening	Decrease number and times of door opening
Too high noise	The unit is not level	Adjust the adjustable foots
	The fastener of the unit is loose	Fasten the loose fastener
	Pipes are touching the compressor	Carefully separate the touching pipes
Lamp is not on	The lamp is burned out	Replace the lamp



# Technical Service Information

## --Exploded view of CTD-3

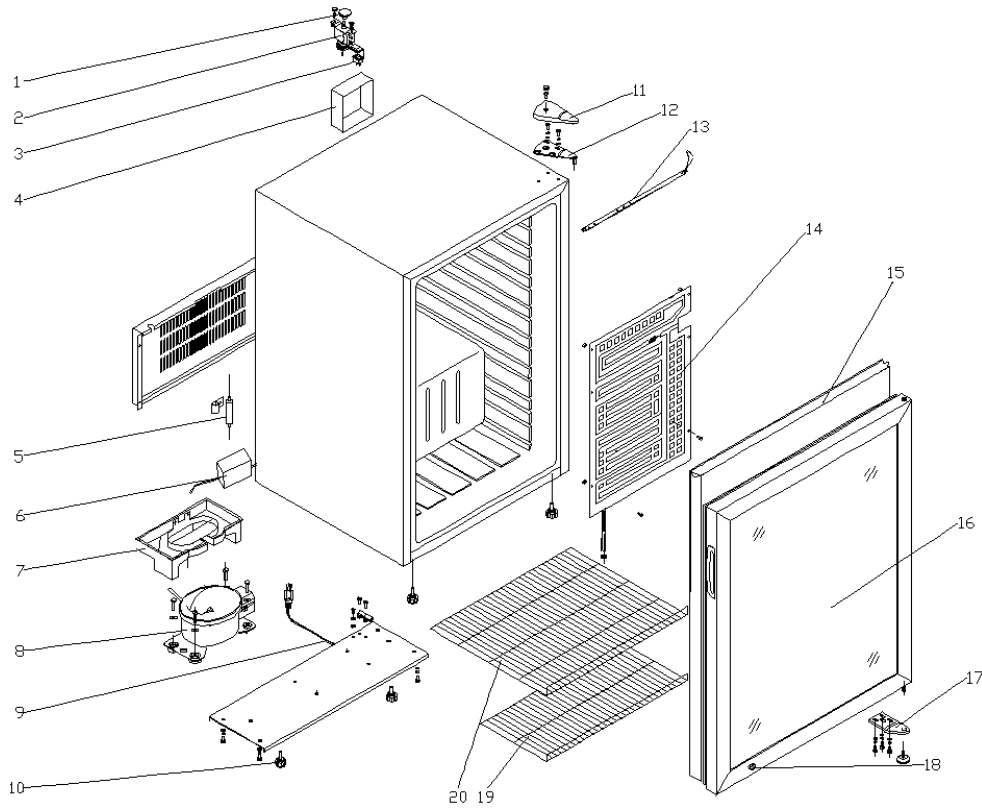

## --Part list of CTD-3

No in explode view	Part number	Description	Qty.
1	CTD001	Thermostat knob	1
2	CTD002	Thermostat (WP1)	1
3	CTD003	ON/OFF button	1
4	CTD004	Temperature control box	1
5	CTD005	Filter (Ø16 * 30)	1
6	CTD006	Constant current power supply	1 AC85v-265v-15D
7	CTD007	Water receiving plate	1
8	CTD008	Compressor (UKN43YA)	1
9	CTD009	Power line (JT-3)	1
10	CTD010	Base foot	4
11	CTD011	Hinge cover	1
12	CTD012	Hinge upper	1
13	CTD013	Led lamp	1
14	CTD014	Evaporimeter	1
15	CTD015	Door seal	1
16	CTD016	Door	1
17	CTD017	Hinge down	1
18	CTD018	Lock	1
19	CTD019	Shelf bottom	1
20	CTD020	Shelf top	2

**--Exploded view of CTD-3S**

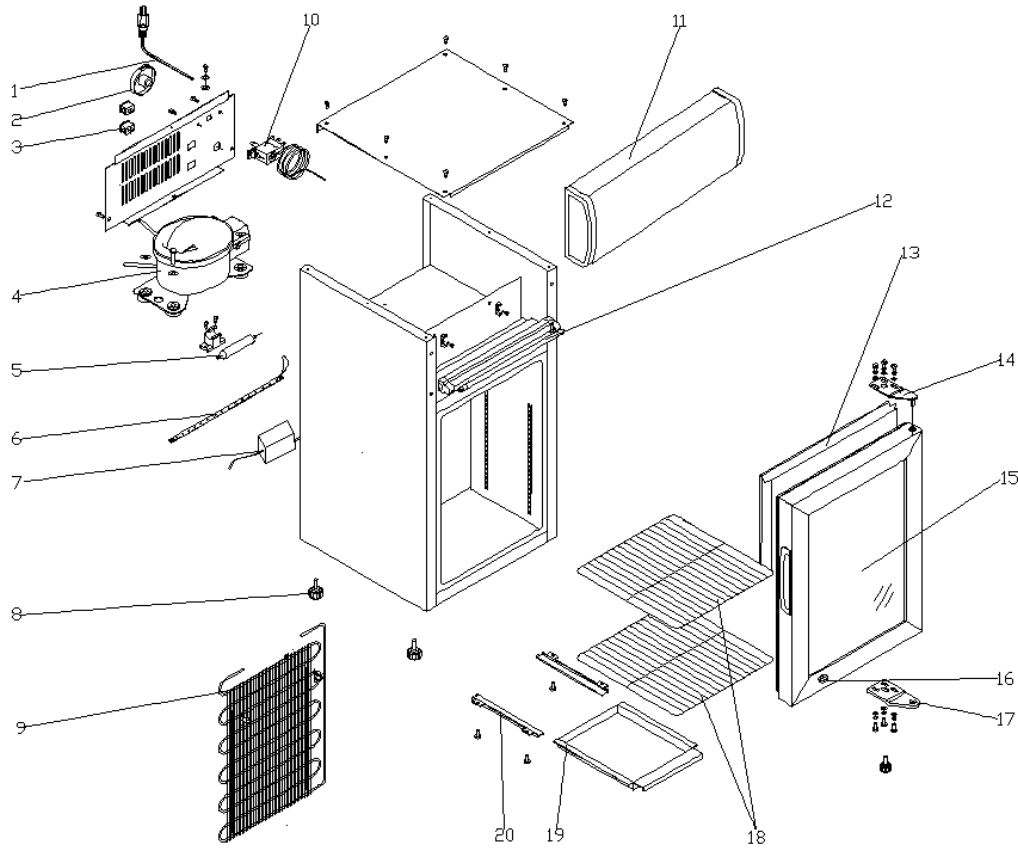

**--Part list of CTD-3S**

No in explode view	Part number	Description	Qty.
1	CTD009	Power line (JT-3)	1
2	CTD021	Thermostat knob	1
3	CTD003	ON/OFF button	2
4	CTD022	Compressor (UKN60YA)	1
5	CTD005	Filter (Ø16 * 30)	1
6	CTD023	Led lamp	1
7	CTD006	Constant current power supply	1
			AC85v-265v-15D
8	CTD010	Base foot	4
9	CTD024	Condenser	1
10	CTD002	Thermostat (WP1)	1
11	CTD025	Lamp plate	1
12	CTD026	Lamp	1
13	CTD027	Door seal	1
14	CTD028	Hinge upper	1
15	CTD029	Door	1
16	CTD018	Lock	1
17	CTD030	Hinge down	1
18	CTD031	Shelf	3
19	CTD032	Water receiving plate	1
20	CTD033	Guide	2

## --Exploded view of CTD-5

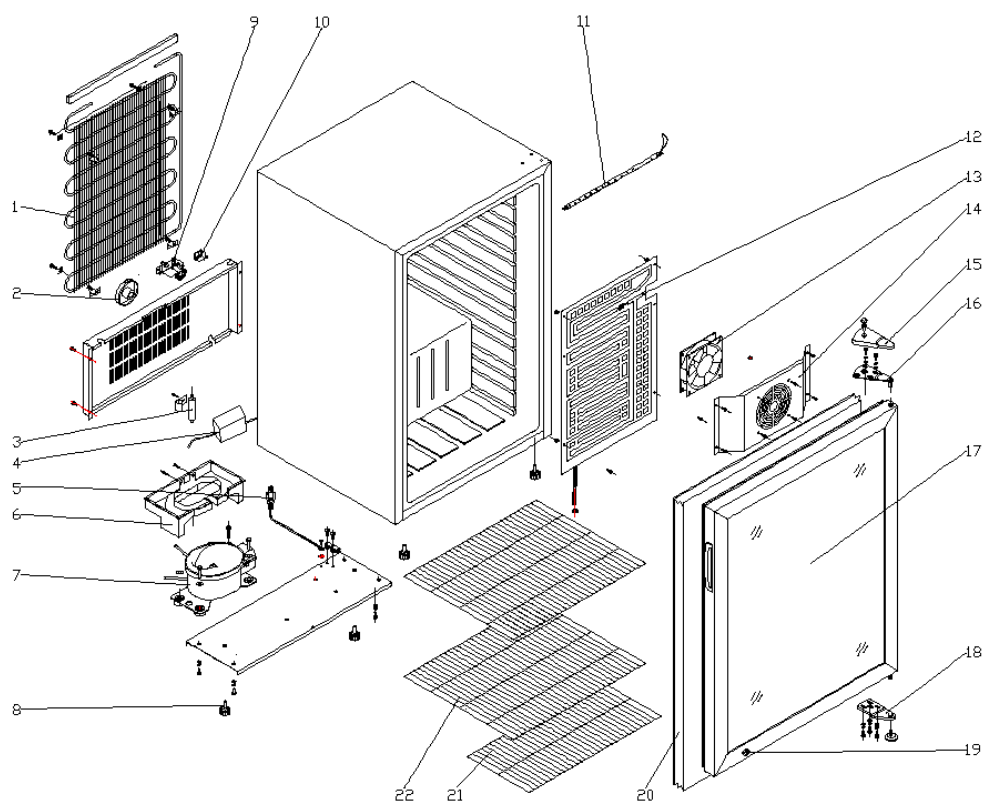

## --Part list of CTD-5

No in explode view	Part number	Description	Qty.
1	CTD034	Condenser	1
2	CTD001	Thermostat knob	1
3	CTD005	Filter (Ø16 * 30)	1
4	CTD006	Constant current power supply	1
5	CTD009	Power line (JT-3)	1
6	CTD035	Water receiving plate	1
7	CTD022	Compressor (UKN60YA)	1
8	CTD010	Base foot	4
9	CTD002	Thermostat (WP1)	1
10	CTD003	ON/OFF button	1
11	CTD036	Led lamp	1
12	CTD037	Evaporimeter	1
13	CTD038	Fan	1
14	CTD039	Fan cover	1
15	CTD011	Hinge cover	1
16	CTD041	Hinge upper	1
17	CTD042	Door	1
18	CTD043	Hinge down	1
19	CTD018	Lock	1
20	CTD044	Door seal	1
21	CTD045	Shelf bottom	1
22	CTD046	Shelf top	3

# --Electric Connection Diagram

## CTD-3 Diagram

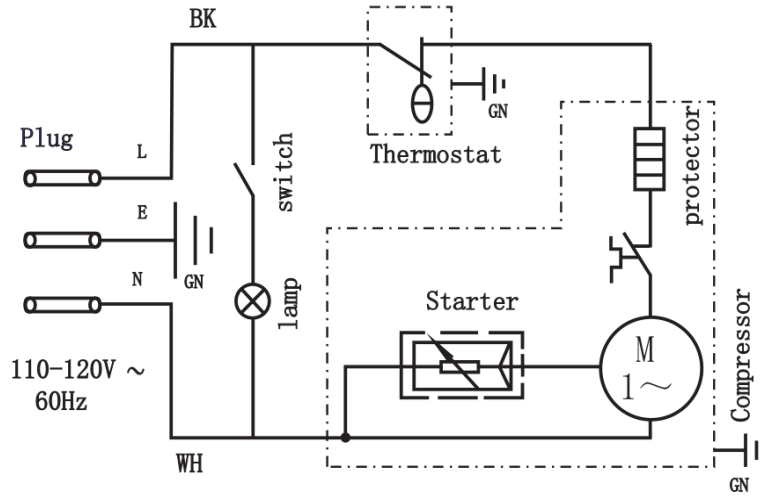

## CTD-3S Diagram

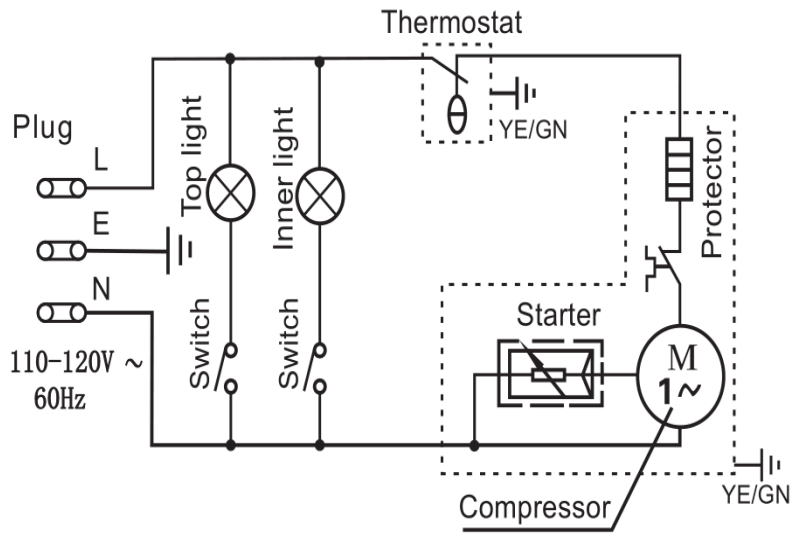

## CTD-5 Diagram

