

Cleaning, Care & Maintenance

⚠ WARNING Unplug the machine power cord and turn the index knob fully clockwise to close the gauge plate before cleaning the slicer.

⚠ WARNING The slicer knife is very sharp. Exercise extreme caution when working near the knife.

- Always turn off and disconnect the appliance from the power supply before cleaning.
- Always use extreme care when handling the blade.
- Use soapy water (comply to EPA regulation) and a damp cloth to clean the appliance.
- If a chemical sanitizer other than chlorine, iodine or quaternary ammonium is used, it shall be applied in accordance with the EPA-registered label use instruction.
- This slicer line shall be cleaned and sanitized at intervals to comply with national, state and/or local health codes or regulations.
-

Cleaning the Blade and Cover

1. Disconnect the appliance from the power supply.
2. Push the carriage away from the blade.
3. The blade cover release bolt.
4. Carefully lift off the blade cover.
5. Wash the blade by wiping from the center towards the edge. **NEVER MOVE YOUR HAND TOWARDS THE EDGE OF THE KNIFE.**
6. Sanitize and dry thoroughly.
7. Replace the cover, ensuring the blade securing bolt is securely tightened.

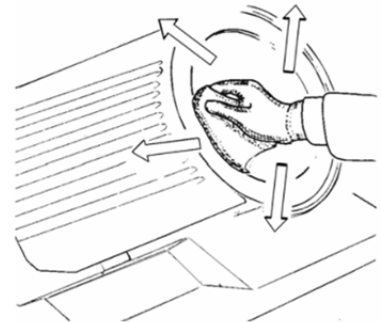

Cleaning and Checking the Food Receiving Area

- After every time of use of slicer, a complete cleaning and checking at food receiving area is necessary.
- Move forward to take off slicer deflector from back of blade support, and clean it.
- Clean all food receiving area and gage plate holder and gasket for thickness adjustment moving.
- Please ask technician to replace and repair if you find any damage and missing of parts in slicer.

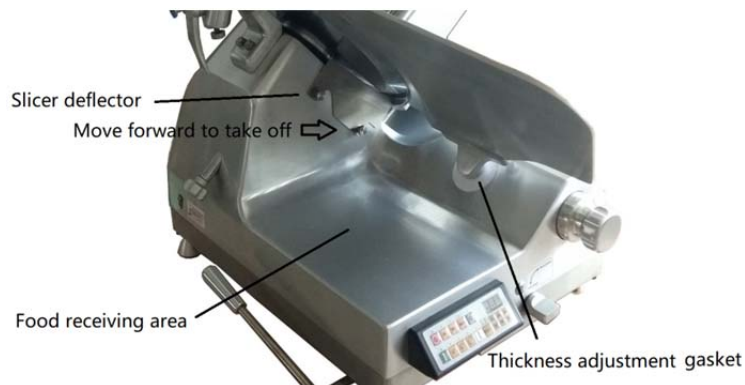

NOTE: The appliance will not work with the blade cover release bolt unscrewed.

NOTE: Recommend the use of cut-resistant or wire mesh gloves when cleaning

NOTE: Recommend using USDA approved sanitizer for cleaning.

Cleaning and Checking the Food Pusher and Food Chute Area

1. After every time of use, a complete cleaning and checking at food pusher and chute area is necessary.
2. Turn the pusher to clockwise direction, pull pusher up through its shaft to the end.
3. Clean all food chute area & pusher, special clean effort need to put at the nail side of pusher face to food.
4. Please ask technician to replace and repair if you find any damage and missing of parts in slicer.

Lubricating

If both the Knife ON LED light and Auto ON LED light are blink at the same time, this is remind you to lubricate. It is not malfunction and not affect the function. You can cancel this blink by pressing the Knife OFF button and Auto OFF button at the same time for 5 seconds.

Lubricate Carriage Slide Guides

Lubricate the carriage slide guides at least once a month and any time that pushing the tray becomes difficult. Use the oil supplied with the slicer or a food safe lubricant. Do NOT use cooking oil.

1. Press and release the OFF (O) button.
2. Unplug the slicer from the electrical outlet.
3. Put a few drops of the oil that was supplied with slicer into the carriage slide lubricant access hole (OIL) on the front of the slicer.

Sharpener shaft also need to lubricated as the arrow show.

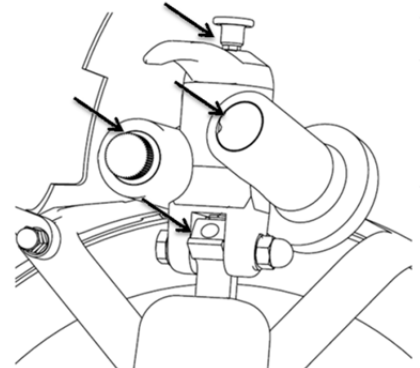
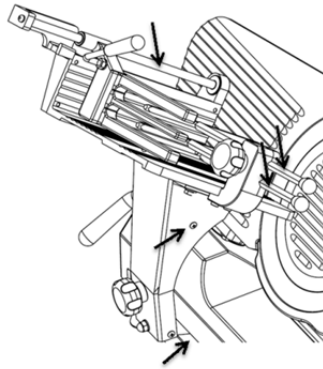
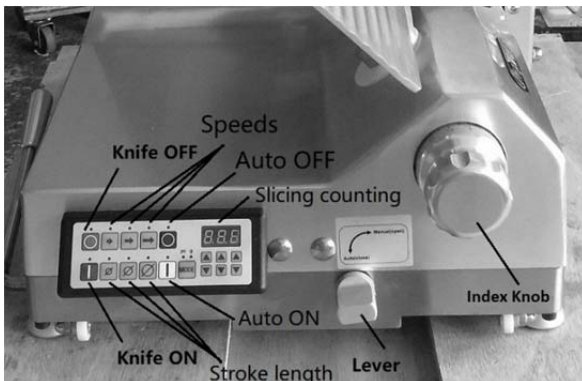

NOTE: Ensure you use a grease that is suitable for use in a food preparation area.

Under the Slice

The Slicer is equipped with **Kickstand** to assist in cleaning under the slicer. To raise the slicer, lift up the handle and rotate to the control panel until it stops. The kickstand will hold the slicer in position for cleaning. Rotate down the kickstand handle to lower the slicer.

NOTE: Do not lift or lower the slicer with the control panel.

