



**"WE MAKE THE KITCHEN BETTER!"**

**ATOSA USA, INC.**

**Toll Free: 855-855-0399 Email: info@atosausa.com**

www.atosa.com | www.atosausa.com

California, Colorado, Florida, Georgia, Illinois,  
New Jersey, Ohio, Texas, Washington

**MODELS:**  
**ATHOM-28 / ATHOM-39 / ATHOM-60**

# Open Air Merchandisers

## Standard Features

- Black exterior & stainless steel interior
- Digital temperature controller and display
- Maintains temperatures between 33°F – 40°F
- Glass side and front panels
- LED interior lighting under shelf and interior top
- One stainless steel shelf and one floor shelf
- Pre-installed casters

## Optional Accessories

- Top Mount Dry Display Case



**ATHOM-28**



**ATHOM-39**



**ATHOM-60**

For the best results of food preservation we recommend setting your refrigerator between 33°F to 38 °F

1. Don't forget to leave the unit some room to breathe!
2. Please clean the condenser frequently to give the unit more fresh air.



**2 YEAR PARTS AND LABOR WARRANTY**  
**5 YEAR COMPRESSOR PART WARRANTY**





**"WE MAKE THE KITCHEN BETTER!"**

**ATOSA USA, INC.**

Toll Free: 855-855-0399 Email: [info@atosausa.com](mailto:info@atosausa.com)

[www.atosa.com](http://www.atosa.com) | [www.atosausa.com](http://www.atosausa.com)

California, Colorado, Florida, Georgia, Illinois,

New Jersey, Ohio, Texas, Washington

## SPECIFICATIONS

Models	Capacity (Cu.Ft.)	Voltage (V/Hz/Ph)	HP	Refrigerant	NEMA Plug	Exterior Dimensions (inch)	Packaging Dimensions (inch)	Shelf Dimensions (inch)	Net Weight (lb)	Gross Weight (lb)
ATHOM-28	4.1	115/60/1	3/5	R290	5-20P	26 <sup>13/16</sup> ×34 <sup>9/16</sup> ×44 <sup>3/8</sup>	29 <sup>9/10</sup> ×37 <sup>3/5</sup> ×49 <sup>2/5</sup>	22 <sup>3/4</sup> ×11	145	180
ATHOM-39	6.18	115/60/1	3/5	R290	5-20P	38 <sup>5/8</sup> ×34 <sup>9/16</sup> ×44 <sup>3/8</sup>	41 <sup>7/10</sup> ×37 <sup>3/5</sup> ×49 <sup>2/5</sup>	34 <sup>9/16</sup> ×11	200	244
ATHOM-60	10.27	115/60/1	3/5	R290	5-20P	62 <sup>1/4</sup> ×34 <sup>9/16</sup> ×44 <sup>3/8</sup>	65 <sup>2/5</sup> ×37 <sup>3/5</sup> ×49 <sup>2/5</sup>	58 <sup>3/16</sup> ×11	254	312

## PLAN VIEW

**ATHOM-28**

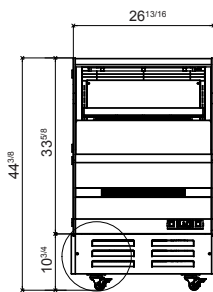

**ATHOM-39**

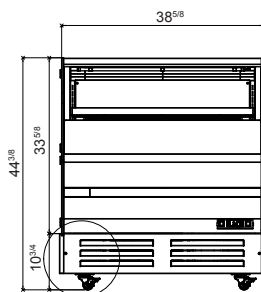

**ATHOM-60**

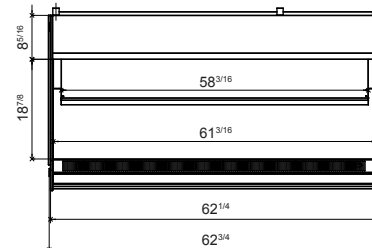
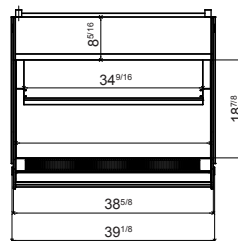
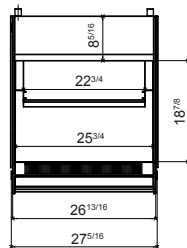
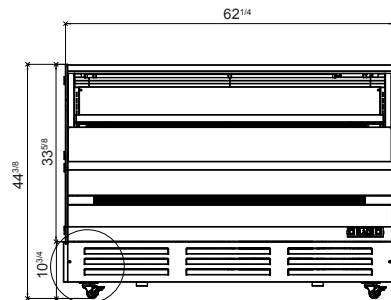

**Side View**

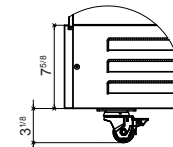
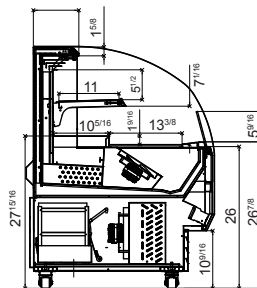
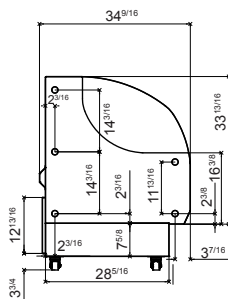

### Electronic Temp. Controller

