



“WE MAKE THE KITCHEN BETTER!”

ATOSA USA, INC.

Toll Free: 855-855-0399 Email: info@atosausa.com

www.atosa.com | www.atosausa.com

California, Colorado, Florida, Georgia, Illinois,  
New Jersey, Ohio, Texas, Washington

# Refrigerated Countertop Prep Station

## Standard Features

- Stainless steel exterior & interior
- Electronic temperature controller
- Side mount compressor with environmentally friendly R290 refrigerant
- Maintains temperatures between 35°F – 38°F
- Includes (10) 1/6 size 6” deep poly pans

MODELS:
MSCT-48-10



For the best results of food preservation we recommend setting your refrigerator between 35°F to 38 °F

1. Don't forget to leave the unit some room to breathe!
2. Please clean the condenser frequently to give the unit more fresh air.



2 YEAR PARTS AND LABOR WARRANTY  
5 YEAR COMPRESSOR PART WARRANTY





**"WE MAKE THE KITCHEN BETTER!"**

**ATOSA USA, INC.**

**Toll Free: 855-855-0399 Email: info@atosausa.com**

www.atosa.com | www.atosausa.com

California, Colorado, Florida, Georgia, Illinois,

New Jersey, Ohio, Texas, Washington

**SPECIFICATIONS**

Models	Door	Capacity (Cu.Ft.)	Voltage (V/Hz/Ph)	Power (W)	Rated Current (A)	Energy Consumption (kw/day)	HP	Refrigerant	Exterior Dimensions (inch)	Net Weight (lb)	Gross Weight (lb)
MSCT-48-10	1	1.5	115/60/1	180	1.7	0.51	1/7	R290	50 <sup>1/8</sup> ×15 <sup>9/16</sup> ×10 <sup>9/16</sup>	61.7	108

**PLAN VIEW**

**MSCT-48-10**

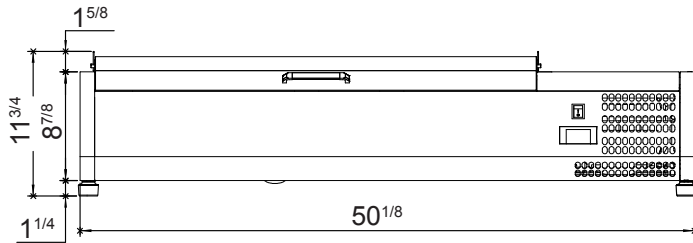

**Front View**

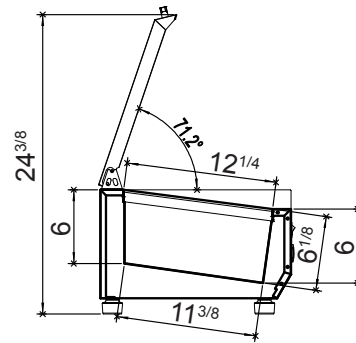

**Side View**

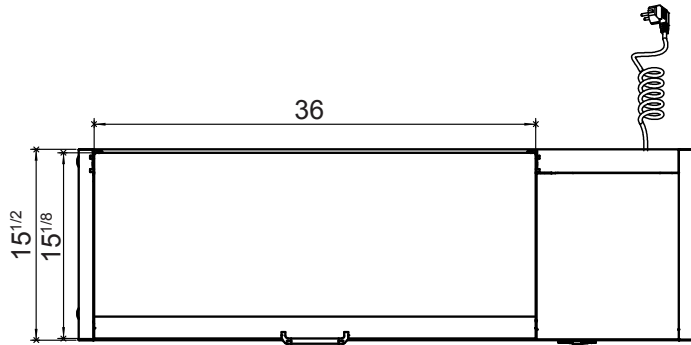

**Top View**

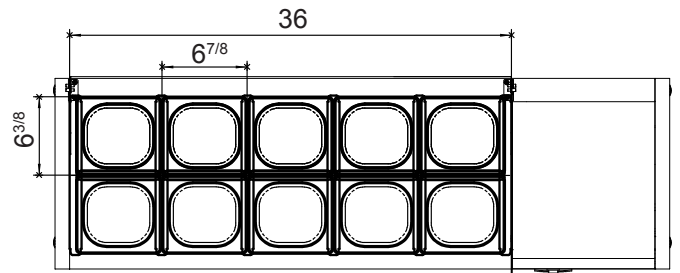

**Interior**

